



## BUS NETWORK TECHNOLOGY

Fike introduces the use of bus network technology to the explosion protection industry. EPACO is using bus network technology to exchange information between EPACO components, and to 'connect' protection controllers to 'enlarge' the protected area if required.

The Annunciator Module (AM) is a local call-in point for all connected devices of a bus. In figure 1 below, a full setup is shown with the maximum number of each type of component that can compose a 'Single Loop'. In practical terms, a loop collects explosion protection controls of a larger protected area containing two or more connected vessels that are being protected.

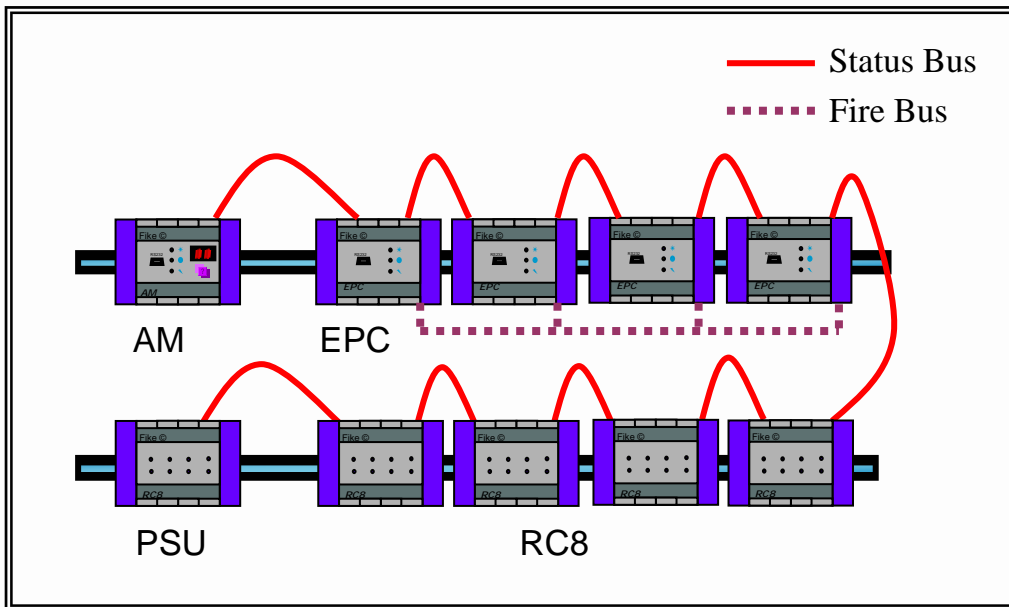
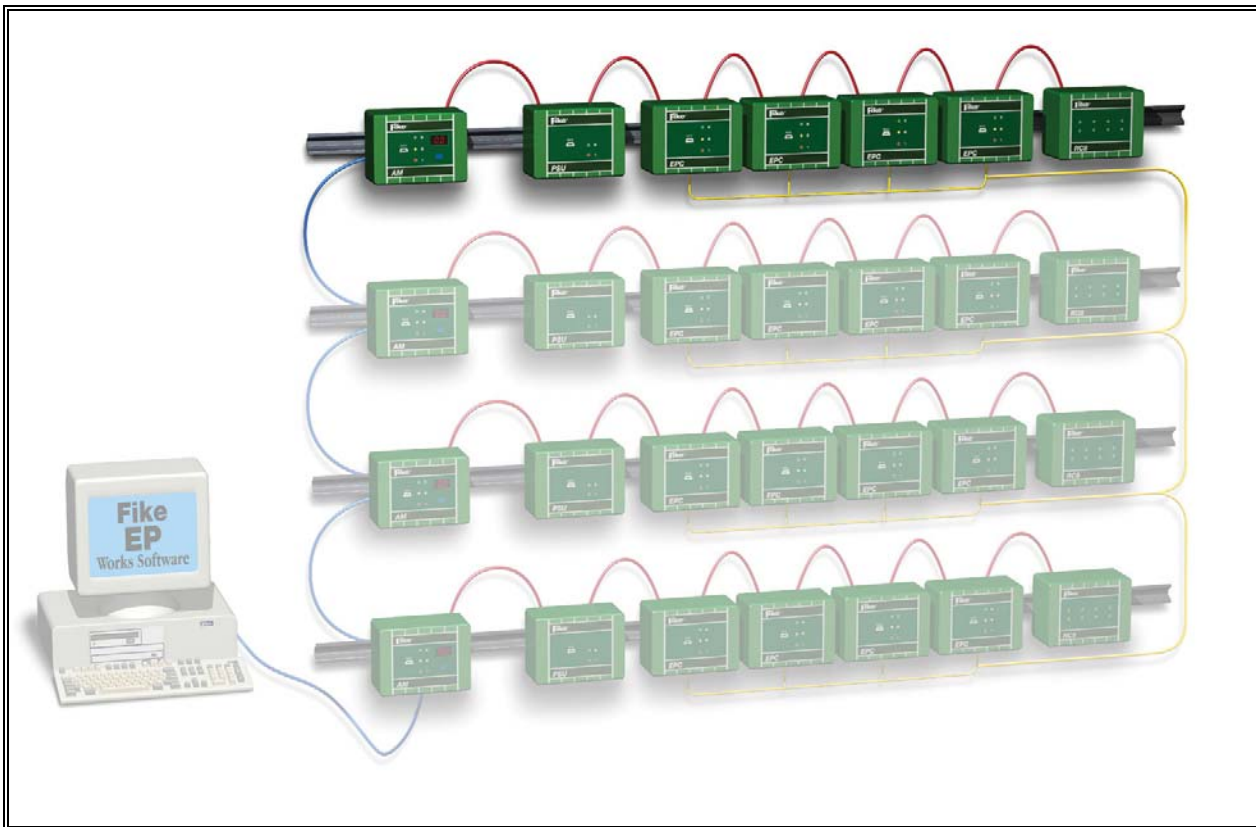

Figure 1: Single Loop Schematic Representation of EPACO Bus Network

Multiple Annunciator Modules can be connected together to form larger systems as shown in figure 2.



*Figure 2: Multi-Loop Schematic Representation of EPACO Bus Network*

The EPACO System utilizes three bus systems a fire bus, a status bus, and a remote bus.

The Fire Bus circuit is a high speed programmable network for output, input, or both (default). When the EPC has received the activation signal from its detection device, it sends a fire signal output through the fire bus to all EPCs in the protection zone. Any EPC that is programmed to respond to a fire signal from this particular EPC will output through its series firing circuit to discharge its devices. The network can initiate up to 16 modules within 2 milliseconds.

The Status Bus is a low speed communication bus that transmits control information between the EPC, Power Supply, Annunciator Module and Relay Modules. The status bus ties all the various modules together to form a network for reporting of system status to the Annunciator Module.

The Remote Bus is a low speed network connection that interconnects all of the Annunciator Modules for central annunciation of all protected loops at a permanently attached computer for system monitoring. This network is provided to support future upgrades to the EPACO system – features associated with this network are currently not implemented.

The number and type of devices used in a loop is driven by:

1. The number of EPCs involved in the protected area. Hereby, the following needs to be considered:
  - Two (2) is the maximum number of 4-20 mA detection transducers that can be connected to an EPC, eventually additional switch type detectors can be connected. It is also possible, if the protection design is made accordingly, to use multiple, parallel wired, switch type detectors as the sole method of detection (\*Also refer to section Frequently Asked Questions for more information).
  - Each EPC has one (1) output to activate simultaneously a maximum of six (6) actuators or protection devices, wired in series. If for instance the volume/geometry of the vessel to be protected requires the use of more than six (6) actuators, a second EPC can be added to the loop. The two (2) EPCs protecting that vessel are connected through the 'fire bus' (see figure above).

The table below details the number of GCAs used per component.

Component	Number of GCAs per component
Suppression Container	1
Isolation Valve 2-10"	1
Isolation Valve 12-18"	2
Isolation Valve 20"	3

2. The number and type of relay contacts required for establishing an interface between EPACO and the overall process control system. Each EPC is equipped with 2 relays: 1 relay output to indicate alarm/release (NO/NC type, 24 V – 1A resistive load, to be energized in a non-alarm/unreleased state) and 1 relay output to indicate trouble/supervisory (NO/NC type, 24 V – 1A resistive load, to be energized in a non-trouble/supervisory state). If more relays or relays that switch on different events are required, a Relay Card (RC8, adding 8 relay contacts, powered by PSU) can be added to the loop.
3. Power supply through the Power Supply Unit (PSU) (and connected transformer/batteries) is required when more than one (1) EPC is used, or as soon as devices other than the EPC are involved.

The benefits that an advanced bus network offers can be summarized as follows:

- Simplified explosion protection system design and configuration
- Easier and more economic installation, less cabling involved
- Faster commissioning, debugging and startup
- New devices can be added by simply attaching them to the bus. No tracing or labeling of circuits is required
- One configuration software package can be used for all connected devices
- Commissioning and diagnostics can be remotely performed from the Annunciator Module (AM) of that protection loop. In this way, information regarding field instruments' health, historical trending can be accessed remotely. This is important since enclosures of live powered circuitry/controls cannot be opened when installed in hazardous areas.
- The local EPC provides power to connected field instruments; no additional external power is required.
- Improved process reliability because control failures tend to be isolated to particular process elements or areas.
- The process of future development of additional instrumentation and control systems is simplified.

For details on electrical wiring and connections, refer to each device's Installation and Operation Instruction manual.

