

FEBRUARY 2000

MILLCENTRIC

OPERATION & MAINTENANCE

MANUAL

SERIES 600

MILLIKEN VALVE COMPANY
1995 HIGHLAND AVENUE, SUITE 500
BETHLEHEM PA 18020
PHONE: (610) 861-8803
FAX: (610) 861-8094

OPERATIONS & MAINTENANCE

OPERATING INSTRUCTIONS

WRENCH OPERATED MILLCENTRIC

Wrench operated Millcentric valves close by turning the valve 90 degrees clockwise.

TORQUE COLLAR

All wrench operated Millcentric valves are equipped with a multifunction device referred to here as a torque collar. This device serves as:

1. Wrench Adapter-2" square
2. Position Indicator
3. Open Memory Stop
4. Closed Memory Stop
5. Running Torque Adjustment

Position Indicator

The top of the plug has an indicator plate to show the approximate plug position. Cast onto the torque collar is an indicator mark which corresponds to a graduated scale cast on the bonnet of the valve. This scale is divided into 15 degree lines and indicates the exact valve opening from full open to full closed.

Open Memory Stop

The torque collar also incorporates an open memory stop feature. The plug can be set by tightening bolt 2 after the correct flow is achieved. The valve can then be closed for maintenance and reopened to the proper position without recheck the flow.

Closed Memory Stop

The closed memory stop is provided to allow for discrepancies in the molded elastomer and to allow for wear of either the plug coating or the seat. The closed stop is pre-set at the factory and should not require readjustment unless substantial wear occurs.

To adjust the plug for excess plug or seat wear simply rotate the closed stop two turns clockwise then rotate the plug (clockwise) further into the seat and check the flow. Should this movement fail to shut off the flow repeat the above step. Afterward re-set the lock nut to prevent the position from being altered.

OPERATIONS & MAINTENANCE

Running Torque Adjustment

The nature of eccentric plug valves "camming" action eliminates the majority of the torque prior to seating- in the running stage. To prevent the plug from creeping open or slamming closed the torque collar maintains a constant drag on the shoulder of the valve bonnet. This adjustment is also factory set and should only be tightened if the valve exhibits the above mentioned creeping or slamming conditions.

To prevent the plug from unnecessary movement rotate the hex head bolt clockwise until there is a substantial drag on the plug but not so much as to prevent the movement of the plug with the supplied wrench.

Wrench Operated Valve With Torque Collar

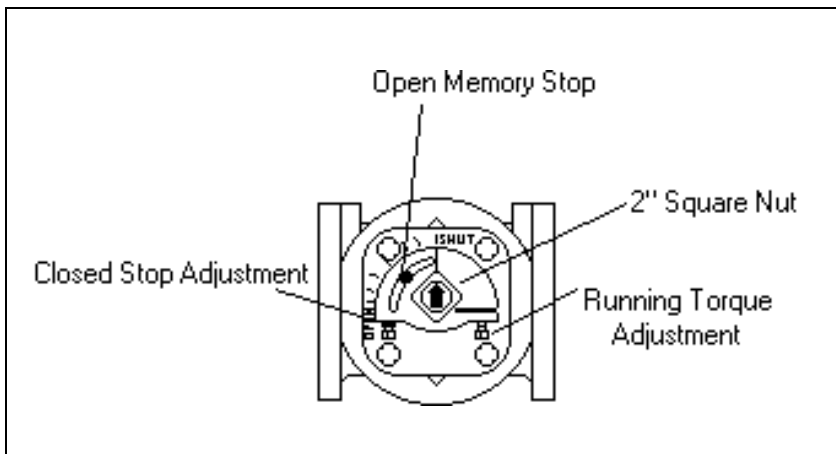

OPERATING INSTRUCTIONS

GEAR OPERATED MILLCENTRIC

Gear operated Millcentric valves close by tuning the gear input shaft clockwise until closed. Please see specific valve drawing for the exact number of turns to close.

Position Indicator

(Above ground units only)

The top of the gear operator has an indicator plate to show the plug position. This scale, cast onto the gear housing, is divided into 15 degree lines and indicates the exact valve opening from full open to full closed. Buried service units are totally enclosed and sealed for use below grade.

Open and Closed Memory Stops

The closed memory stop is provided to allow for discrepancies in the molded elastomer and to allow for wear of either the plug coating or the seat. The closed stop is pre-set at the factory and should not require readjustment unless substantial wear occurs.

To adjust the plug for excess plug or seat wear simply rotate the closed stop two turns clockwise then rotate the handwheel or nut (clockwise) to move the plug further into the seat and check the flow. Should this movement fail to shut off the flow repeat the above step. Afterward re-set the lock nut to prevent the position from being altered.

Gear Operated Valve

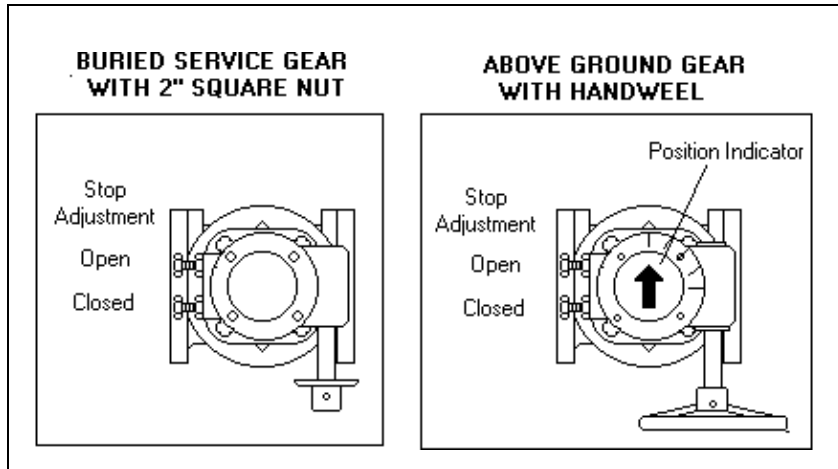

OPERATIONS & MAINTENANCE

MAINTENANCE INSTRUCTIONS

GEAR OPERATED VALVE

The Millcentric is designed and manufactured to be a long life valve under normal circumstances. It does not require any routine maintenance. Cycling the valve from full open to full closed on an annual basis will increase the life of the valve and operator components.

However, if maintenance is required, due to unusual wear or service conditions the following procedure should be followed:

DISASSEMBLY PROCEDURE

BODY

The Millcentric is a top entry valve; therefore the body can remain in line during this operation. Remove the bolts holding the gear operator cap in place. Remove the cap and remove the internal bolts fastening the gear operator to the valve body. Remove the gear operator and set aside. With the valve de-pressurized, remove the hexagonal head cap screws that hold the bonnet to the valve body. Remove the bonnet, leaving the plug in the body. At this point the plug, PTFE thrust washers, journal bearings and bonnet "O" ring are accessible and can be removed and replaced.

Care should be taken not to damage the plug elastomer or bonnet "O" rings upon reassembly.

Reverse the above process for reassembling the Millcentric.

STEM SEALS

Remove the bolts holding the gear operator cap in place. Remove the cap and remove the internal bolts fastening the gear operator to the valve body. Remove the gear operator and set aside.

With the valve de-pressurized, using internal snap ring pliers, remove the snap ring and thrust washer. The "U" cup seals can now be pried out of the seal cavity. To replace reverse the above process.

OPERATIONS & MAINTENANCE

MAINTENANCE INSTRUCTIONS

WRENCH OPERATED VALVE 2-1/2"- 8"

The Millcentric is designed and manufactured to be a long life valve under normal circumstances. It does not require any routine maintenance..

However if maintenance is required , due to unusual wear or service conditions the following procedure should be followed:

DISASSEMBLY PROCEDURE

BODY

The Millcentric is a top entry valve; therefore the body can remain in line during this operation. Remove the socket head capscrew fastening the torque collar to the plug stem. Remove the torque collar and set aside. With the valve de-pressurized, remove the hexagonal head cap screws that hold the bonnet to the valve body. Remove the bonnet, leaving the plug in the body. At this point the plug, PTFE thrust washers, journal bearings and bonnet "O" ring are accessible and can be removed and replaced.

Care should be taken not to damage the plug elastomer or bonnet "O" rings upon reassembly.

Reverse the above process for reassembling the Millcentric.

STEM SEALS

Remove the socket head capscrew fastening the torque collar to the plug stem. Remove the torque collar and set aside.

With the valve de-pressurized, using internal snap ring pliers, remove the snap ring and thrust washer. The "U" cup seals can now be pried out of the seal cavity. To replace reverse the above process.

OPERATIONS & MAINTENANCE

MAINTENANCE INSTRUCTIONS

THREADED WRENCH OPERATED VALVE

1/2"- 2"

The Millcentric is designed and manufactured to be a long life valve under normal circumstances. It does not require any routine maintenance..

However if maintenance is required , due to unusual wear or service conditions the following procedure should be followed:

DISASSEMBLY PROCEDURE

BODY

The Millcentric is a top entry valve; therefore the body can remain in line during this operation. Remove the spring pin fastening the torque collar to the plug stem. Remove the torque collar and set aside. With the valve de-pressurized, rotate the bonnet counterclockwise to loosen the bonnet from the valve body. Remove the bonnet, leaving the plug in the body. At this point the plug, journal bearings and bonnet "O" ring are accessible and can be removed and replaced.

Care should be taken not to damage the plug elastomer or bonnet "O" rings upon reassembly.

Reverse the above process for reassembling the Millcentric.

STEM SEALS

Remove the spring pin fastening the torque collar to the plug stem. Remove the torque collar and set aside. With the valve de-pressurized, rotate the bonnet counterclockwise to loosen the bonnet from the valve body. Remove the bonnet, leaving the plug in the body. At this point the stem "O" rings are accessible and can be removed and replaced.

Reverse the above process for reassembling the Millcentric.

OPERATIONS & MAINTENANCE

ACTUATED VALVES

The Millcentric is designed and manufactured to be a long life valve under normal circumstances. It does not require any routine maintenance. Cycling the valve from full open to full closed on an annual basis will increase the life of the valve and operator components.

However, if maintenance is required, due to unusual wear or service conditions, the following procedure should be followed:

DISASSEMBLY PROCEDURE

BODY

The Millcentric is a top entry valve; therefore, the body can remain in line during this operation. Remove the bolts holding the actuator bracket to the valve cap. You can then remove the actuator from the valve. With the valve de-pressurized, remove the hexagonal head cap screws that hold the bonnet to the valve body. Remove the bonnet, leaving the plug in the body. At this point the plug, PTFE thrust washers, journal bearings, and bonnet “O” ring are accessible and can be removed and replaced.

Care should be taken not to damage the plug elastomer or bonnet “O” rings upon reassembly.

Reverse the above process for reassembling the Millcentric.

STEM SEALS

With the valve de-pressurized, using internal snap ring pliers, remove the snap ring and thrust washer. The “U” cup seals can now be pried out of the seal cavity. To replace, reverse the above process.

MAINTENANCE INSTRUCTIONS ACTUATED VALVES TO REPLACE “U” CUP SEALS

The Millcentric is designed and manufactured to be a long life valve under normal operating conditions. It does not require any routine maintenance. Cycling the valve from full open to full closed on an annual basis will increase the life of the valve and actuator components.

However, if maintenance is required, due to unusual wear or service conditions, the following procedure should be followed:

To replace “U” cup seals on actuated Millcentric valves, remove the actuator; remove the internal bolts fastening the actuator to the valve body. Remove the actuator and set aside. Remove the external snap ring and support collar.

Remove the internal snap ring using snap ring pliers. Remove thrust washer. The “U” cup seals are now visible. Using a screwdriver, pry out the old seals.

Apply a small amount of silicone or grease to the new “U” cup seals. This will help them slide in the packing cavity. Put a piece of shim stock into the cavity and put the “U” cup over it. Slide the “U” cup over the stem with shim stock against the stem. This will let any trapped air out of the packing cavity. Now, using two screwdrivers, coax the outer lip of the “U” cup into the cavity while pressing down on the top of the “U” cup with the other screwdriver (see attachment). Continue to do this all the way around until the “U” cup is at the bottom of the packing cavity.

Repeat the procedure with the second “U” cup, and replace the thrust washer and snap ring. Now you can remount the actuator on the valve.

OPERATION & MAINTENANCE

INSTALLATION

When installing the valves, the seat end should be noted. The seat end of the valve is cast in raised letters on the appropriate flange of the valve. Generally, straightway valves should be installed with the highest pressure applied from the opposite end from the seat. This will tend to push the plug into the seat.

In cases where shut-off is required in both directions, the valve should be installed so that the highest differential pressure at shut-off is opposite the seat end.

When the service is of a clogging type likely to build up in the valve body, it is recommended that the valve be installed with the media entering the seat end first. In extreme cases, the valve should be installed with the plug horizontal and rotating upward into the top portion of the valve body cavity to open.

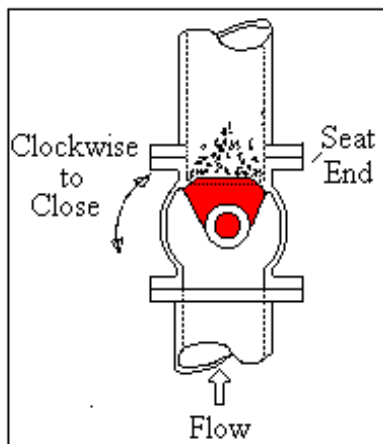

Vertical Pipeline

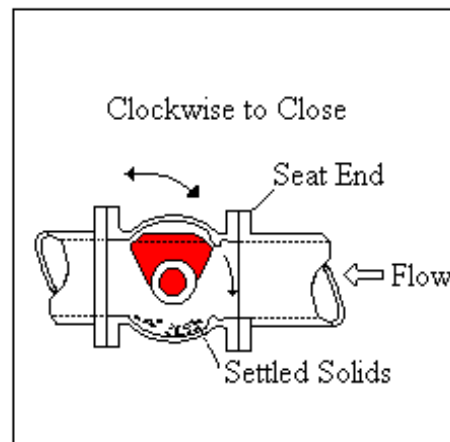

Horizontal Pipeline

Flanged end valves have ANSI B16.1 flat faced 125/150 flanges. Standard ANSI B16.21 flanges and gaskets should be used to install the valves in the pipeline. Certain size valves utilize tapped holes at valve trunnions where a backing nut is not possible. Please check specific drawings for detailed information on sizes and quantities of hexagon head screws required on these valves.

Prior to installing valve, especially ones that are buried, they should be cycled open and closed several times to ensure they are in good working order and have not been damaged during shipment or storage.

OPERATIONS & MAINTENANCE

FUNCTION

The Millcentric valve is a non-lubricated eccentric plug valve designed for use in water and waste water applications, and HVAC systems.

TEMPERATURE LIMITS

The operating temperature is controlled by the elastomer specified and are as follows:

<u>Elastomer</u>	<u>High Temp</u>	<u>Low Temp</u>
Buna N	225 F	-20 F
EPDM	250 F	-35 F
Neoprene	225 F	-20 F
Viton	400 F	-10 F

PRESSURE LIMITS

The operating pressure differs with the valve size range and configuration, and are as follows:

FIGURE 600/601 - ANSI Class 125

<u>Size Range</u>	<u>Rated Pressure*</u>	<u>Shell Hydro</u>	<u>Seat Test</u>
1/2"- 12"	175 psi	350 psi	210 psi
14"- 36"	150 psi	300 psi	180 psi
42"- 54"	125 psi	250 psi	150 psi

* Pressure Ratings are given at ambient temperatures.

OPERATION & MAINTENANCE

SPARE PARTS LIST

<u>COMPONENT</u>	<u>NUMBER PER VALVE</u>
Journal Bearings	2
PTFE Thrust Washers	2
“U” Cup Seals	2
Elastomer Coated Plug	1
Bonnet “O” Ring Seal	1

If required these parts can be ordered from:

**Milliken Valve Company, Inc.
1995 Highland Avenue Suite 500
Bethlehem, PA 18020**

**Tel: (610) 861-8803
Fax : (610) 861-8094**

When ordering please furnish the size, figure number and component name:

For example: 6" Figure 601N1AG- Journal Bearing

OPERATIONS & MAINTENANCE

TROUBLE SHOOTING

Gear Operated Valves

<u>SYMPTOM</u>	<u>POSSIBLE CAUSE</u>	<u>ACTION</u>
Valve Will Not Open.	Bent Input Shaft Obstruction in Line Excessive Line Pressure Elastomer Damage	Replace Worm Shaft Remove Obstruction Reduce Pressure Replace Plug
Valve Will Not Close.	Bent Input Shaft Obstruction in Line Excessive Line Pressure Elastomer Damage	Replace Worm Shaft Remove Obstruction Reduce Pressure Replace Plug
Valve Will Not Shutoff Flow	Improper Stop Adjustment Obstruction in Line Excessive Line Pressure Elastomer Damage	Adjust Closed Stop Remove Obstruction Reduce Pressure Replace Plug
Valve Leaks at Plug Stem	Damaged "U" Cup Seal	Replace "U" Cups

OPERATIONS & MAINTENANCE

TROUBLE SHOOTING

Wrench Operated Valves

<u>SYMPTOM</u>	<u>POSSIBLE CAUSE</u>	<u>ACTION</u>
Valve Will Not Open.	Broken or Misadjusted Torque Collar Obstruction in Line Excessive Line Pressure Elastomer Damage	Adjust or Replace Torque Collar Remove Obstruction Reduce Pressure Replace Plug
Valve Will Not Close.	Broken or Misadjusted Torque Collar Obstruction in Line Excessive Line Pressure Elastomer Damage	Adjust or Replace Torque Collar Remove Obstruction Reduce Pressure Replace Plug
Valve Will Not Shutoff Flow.	Improper Stop Adjustment Obstruction in Line Excessive Line Pressure Elastomer Damage	Adjust Closed Stop Remove Obstruction Reduce Pressure Replace Plug
Valve Leaks at Plug Stem	Damaged "U" Cup Seal	Replace "U" Cups

OPERATIONS & MAINTENANCE

STORAGE PROCEDURE

Milliken valves are shipped with the plugs in the open position. Care should be taken to maintain this position while the valves are in storage prior to installation in the pipeline.

Flanged valve end protectors (if supplied) should be kept on the valves until they are ready for installation. Special care should be given to mechanical joint valves to prevent damage to the internal pipe seating area.

Valves should be stored where internal contamination due to sand and mud can be kept to a minimum. Care should be taken to avoid direct sunlight on the plug elastomer during storage.

Electric, hydraulic and pneumatic valve actuators should be cared for in accordance with the storage instructions of the actuator manufacturer.

OPERATION & MANTENANCE

LUBRICATION SCHEDULE

The Millcentric is a low maintenance non-lubricated eccentric plug valve. As such there is no required lubrication of the valve itself.

The manual worm gear operators where applicable are also sealed grease lubricated units and should not require any type of periodic lubrication. Should the unit need to have lubricant replaced it is recommended that **Shell “Alvania” #2**.