

Sure Seal Series 500/522

Sure Seal Series 500/522 are dimensionally interchangeable with Keystone Fig. 100/122

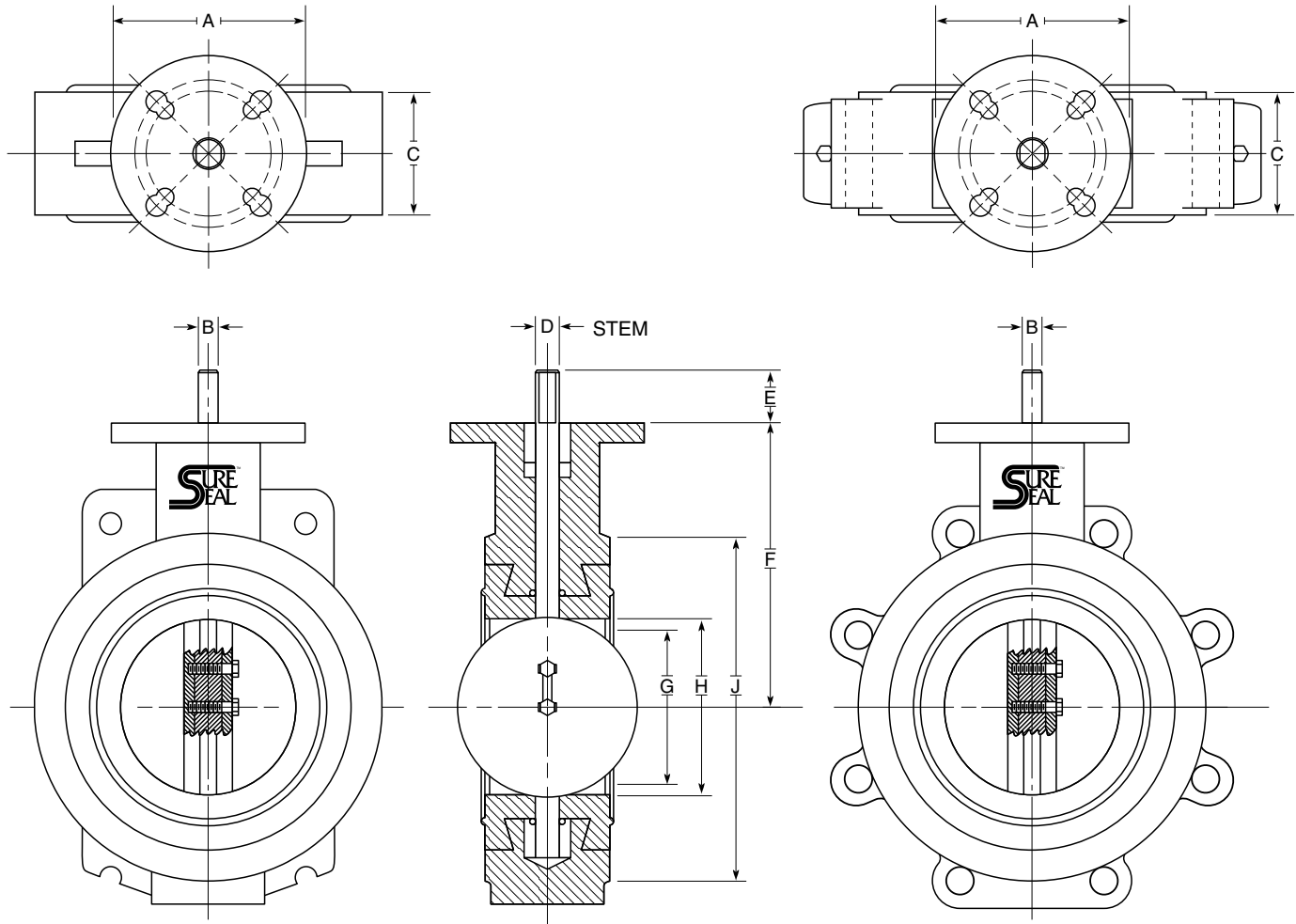

Valve Size

	2	2.5	3	4	5	6	8	10	12
A	4.000	4.000	4.000	4.000	4.000	4.000	6.000	6.000	6.000
B	.375	.375	.375	.438	.438	.438	.500	.625	1.125
C	1.625	1.750	1.750	2.000	2.125	2.125	2.500	2.500	3.000
D	.563	.563	.563	.625	.625	.625	.750	.875	1.125
E	1.250	1.250	1.250	1.250	1.250	1.250	1.250	1.250	2.000
F	3.938	4.500	4.875	6.000	6.000	6.500	8.313	9.000	10.625
G	1.688	2.125	2.875	3.875	5.000	6.000	8.000	10.063	11.938
H	2.125	2.563	3.125	4.125	5.188	6.125	8.125	10.125	12.093
J	4.025	4.825	5.250	6.750	7.625	8.625	10.812	13.375	16.188

Valve Dimension

GENERAL NOTES:

C = INSTALLED WIDTH
 G = MINIMUM ALLOWABLE INSIDE DIA. OF PIPE OR MATING FLANGE
 2"-10" — D = STEM CONNECTION DIA.; B = FLATS
 12" — D = STEM CONNECTION DIA.; KEYWAY = .250 X .250
 * Weight based on Nodular Iron Disc, Cast Iron Body and EPDM Seat.

VELOCITY LIMITS:

FOR ON/OFF SERVICES
 FLUIDS - 30 FT/SEC (9M/S) GASES - 175 FT/SEC (54 M/S)

Purchasers are expected to make their own tests to determine the suitability of these products for their particular purposes. The data represented in this flyer is for general information only. Manufacturer is not responsible for acceptability of these products in regard to individual system requirements. For specific performance data and correct materials selection, please contact your Sure Seal Dealer. ©2003 Sure Seal, Incorporated • Printed in the USA

Rt. 2, Box 2242 • Mineral Point, Missouri 63660 • (573) 438-5000 • Fx (573) 438-4853
 www.suresealinc.com • ssi@suressealinc.com

Top Plate Drilling

	2	2.5	3	4	5	6	8	10	12
No. Holes	4	4	4	4	4	4	4	4	4
BC	3.250	3.250	3.250	3.250	3.250	3.250	5.000	5.000	5.000
Hole Dia.	.438	.438	.438	.438	.438	.438	.563	.563	.563
ISO BC	2.760	2.760	2.760	2.760	2.760	2.760	4.020	4.020	4.020
ISO Hole Dia.	.38	.38	.38	.38	.38	.38	.41	.41	.41

Weight in Pounds*

	2	2.5	3	4	5	6	8	10	12
500	6	8	9	13	15	19	31	47	88
522	8	10	11	17	21	26	42	65	108

Lug Tapping Data

	2	2.5	3	4	5	6	8	10	12
Bolt Circle	4.750	5.500	6.000	7.500	8.500	9.500	11.750	14.250	17.000
No. Holes	4	4	4	8	8	8	8	12	12
Tap	.625-11 UNC			.750-10 UNC			.875-9 UNC		



1-800-382-1604

Making a big difference to your bottom line.